

Simon

Caratteristiche
Features



- Rivestimenti in tessuto completamente sfoderabili.
Fully removable fabric covers.
- Cuscini schienale in vera piuma canalizzata, garantita Assopiuma, ricoperti in tessuto in puro cotone a tenuta di piuma.
Back cushions in real canalized down, guaranteed Assopiuma, covered in pure downproof cotton fabric.
- Struttura in legno massello e derivati leggeri, con imbottitura in poliuretano espanso, il tutto rivestito in vellutino.
Structure in solid wood and light derivatives, with polyurethane foam padding, all covered in velveteen.
- Cuscini seduta in poliuretano espanso a densità differenziate con strato superficiale in memory foam, rivestiti in vellutino.
Seat cushions in polyurethane foam with different densities with a surface layer of memory foam, covered in velveteen.
- Piedi in fusione di alluminio disponibili nella finitura bronzata.
Feet in cast aluminum available in bronzed finish.

Variazioni
Variations



PIEDI IN FUSIONE DI ALLUMINIO
FEET IN CAST ALUMINUM



TELAIO IN FUSIONE DI ALLUMINIO CON FINITURA BRONZATA
CAST ALUMINUM FRAME IN BRONZED FINISH

A richiesta è disponibile un telaio in fusione di alluminio con finitura bronzata, con un supplemento
Si prega di specificare le finiture al momento dell'ordine.

Upon request a cast aluminum frame in bronzed finish is available at an additional cost. Please specify finishings upon order.

Elementi
Elements

SIMCP100

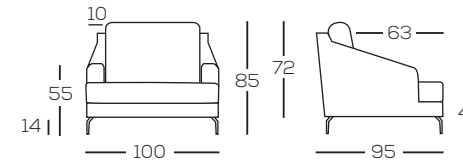

SIMCD180



SIMCD200

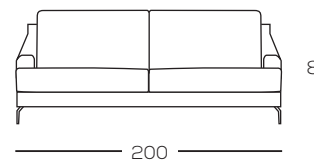

SIMCD220

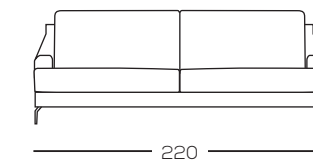

SIMCD240

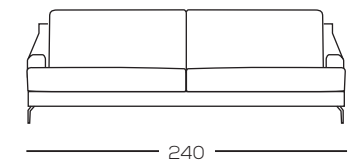

SIMCD260

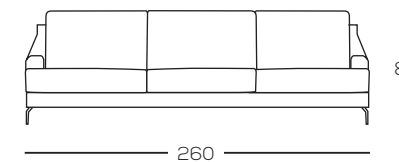

SIMCT170 Dx/Sx

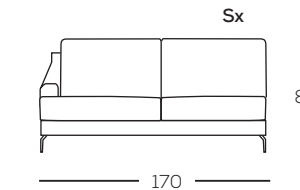

SIMCT190 Dx/Sx

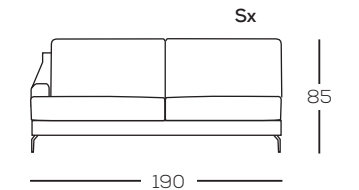

SIMCT210 Dx/Sx

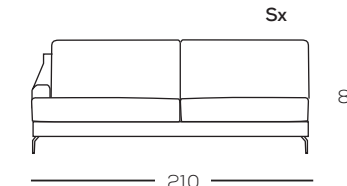

SIMCT230 Dx/Sx

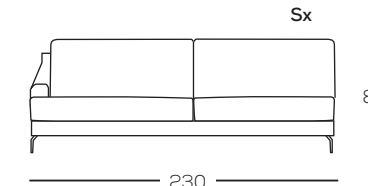

SIMCT250 Dx/Sx



SIMCR170 Dx/Sx

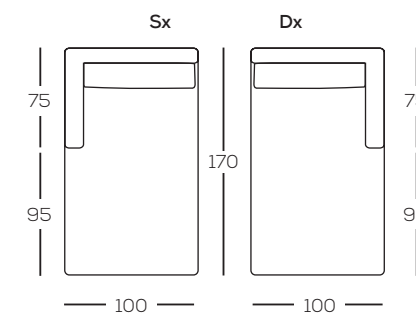

SIMCA95 Dx/Sx

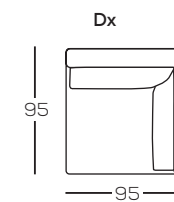

SIMCTA220 Dx/Sx

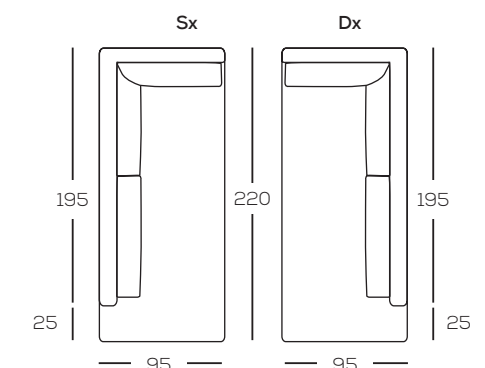

SIMCPF95

